

PLANER/JOINTER/MOULDER KNIVES

PLANER/JOINTER KNIVES

PLANER & JOINTER KNIVES

T-1 HIGH-SPEED STEEL (HSS)

18% TUNGSTEN

New grade T-1 high-speed steel with **18%** tungsten content. For comparison, this steel is much harder than M-2 HSS which typically has **12%** tungsten. Crafted on state-of-the-art equipment in Germany, using German steel, each knife is ground, honed and individually hand-hammered to exacting tolerances. Many standard sizes available individually or in sets. For a nominal charge, knives can be cut to length. **PACKAGING:** Bulk in flat tubes.

HSS PLANER & JOINTER INDIVIDUAL KNIVES (each)

T-1 HIGH-SPEED STEEL (HSS)

18% TUNGSTEN

Tool No.	Dimension (Inches)				a°
	L	W	t		
P 445	15	1	1/8	45°	
NEW P 442	16	1	1/8	45°	
P 450	20	1	1/8	45°	
P 455	20	35MM	1/8	45°	
P 480	24	1	1/8	45°	
P 490	24	1-1/4	1/8	45°	
P 495	24	35MM	1/8	45°	
P 520	24	11/16	5/32	45°	
P 560	25	3/4	1/8	45°	
P 570	25	7/8	1/8	45°	
P 580	25	1	1/8	45°	
P 590	25	1-1/4	1/8	45°	
P 595	25	35MM	1/8	45°	
P 640	31	3/4	1/8	45°	
P 650	31	1	1/8	45°	
P 660	31	1-1/4	1/8	45°	
P 700	37	5/8	1/8	45°	
P 710	37	3/4	1/8	45°	
P 715	37	7/8	1/8	45°	
P 720	37	1	1/8	45°	
P 726	37	1-1/8	1/8	45°	
P 730	37	1-1/4	1/8	45°	
P 772	37	1-1/2	1/8	45°	
P 740	37	5/8	3/32	45°	
P 750	37	3/4	3/32	45°	
P 712	37	3/4	5/32	45°	
P 722	37	1	5/32	45°	
P 762	37	1-1/8	5/32	45°	
P 770	37	1-1/4	5/32	45°	
P 774	37	1-1/2	5/32	45°	

METRIC SIZES

Tool No.	L	W	t	a°
NEW P 727	37	30MM	3MM	45°
P 725	37	30MM	1/8	45°
P 735	37	35MM	1/8	45°
P 724	400MM	30MM	3MM	45°
P 732	400MM	35MM	3MM	45°
P 734	500MM	35MM	3MM	45°
P 457	600MM	35MM	3MM	45°
P 458	1 meter	35MM	3MM	45°

HSS PLANER & JOINTER KNIFE SETS

T-1 HIGH-SPEED STEEL (HSS)

18% TUNGSTEN

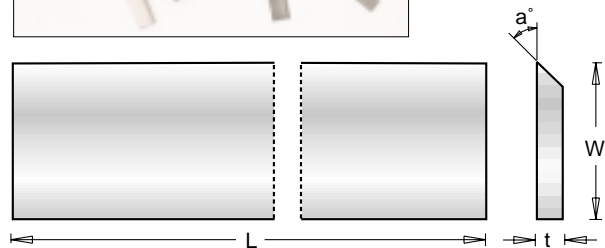

Tool No.	L	W	t	a°	Knives Per Set
P 100	4	5/8	1/8	45°	3
P 110	4	3/4	1/8	45°	3
P 130	4-3/8	5/8	1/8	45°	3
P 150	6	5/8	1/8	45°	3
P 160	6	5/8	1/8	45°	4
P 165	6	3/4	1/8	45°	3
P 170	6	7/8	1/8	45°	3
P 190	6-1/16	5/8	3/32	45°	3
P 220	6-1/8	5/8	1/8	45°	3
P 230	6-1/8	3/4	1/8	45°	3
P 250	8	5/8	1/16	45°	4
P 270	8	5/8	1/8	45°	3
NEW P 280	8	3/4	1/16	45°	3
P 290	8	3/4	1/8	45°	3
P 300	8	7/8	1/8	45°	3
P 310	8	1	1/8	45°	3
P 340	8-1/16	5/8	3/32	45°	3
P 360	12	5/8	1/8	45°	3
P 370	12	3/4	1/8	45°	3
P 380	12	7/8	1/8	45°	3
P 390	12	1	1/8	45°	3
P 395	12	1-1/4	1/8	45°	3
P 410	12-1/4	3/4	1/8	45°	3
P 420	12-1/4	1	1/8	45°	3
P 430	12-1/2	7/8	1/8	45°	3
P 431	12-1/2	11/16	1/8	45°	3
P 440	13-1/8	11/16	5/32	45°	3
P 443	16-1/4	1-1/4	5/32	45°	3
P 444	18	1-1/4	5/32	45°	3
P 446	18-1/8	1-1/8	5/32	45°	3
P 448	18-1/4	1-1/4	5/32	45°	3
P 452	20-1/4	1-1/4	5/32	45°	3

METRIC SIZES

Tool No.	L	W	t	a°	Knives Per Set
NEW P 120	100MM	30MM	3MM	45°	4
NEW P 140	130MM	30MM	3MM	45°	4
NEW P 180	150MM	30MM	3MM	45°	4
NEW P 240	180MM	30MM	3MM	45°	4
NEW P 345	230MM	30MM	3MM	45°	4

PLANER/JOINTER/MOULDER KNIVES

PLANER/JOINTER/MOULDER KNIVES

PLANER & JOINTER KNIVES SOLID CARBIDE

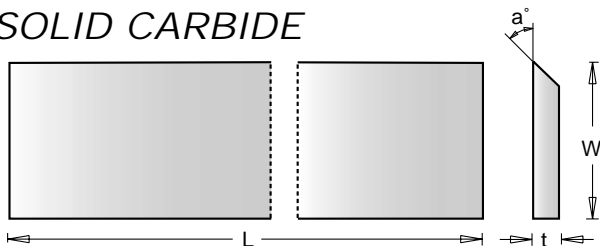

Ready to use: fully ground and honed Solid Carbide micrograin planer & jointer knives. All knives are bevel-edged, and are perfectly parallel and flat, with no mounting holes or slots. Mirror finish, ground from 600 grit diamond wheels. Sold each.

Tool No.	L	W	t	a°
PSC-100	4	5/8	1/8	45°
PSC-110	4	3/4	1/8	45°
PSC-120	6	5/8	1/8	45°
PSC-130	6	3/4	1/8	45°
PSC-140	8	5/8	1/8	45°
PSC-150	8	3/4	1/8	45°
PSC-160	12	3/4	1/8	45°
*PSC-170	12-1/2	3/4	.088	45°
PSC-175	15	1	1/8	45°

*Double-sided (reversible) knives for Delta 12-1/2" planer, model #540.

PLANER & JOINTER KNIVES CARBIDE TIPPED

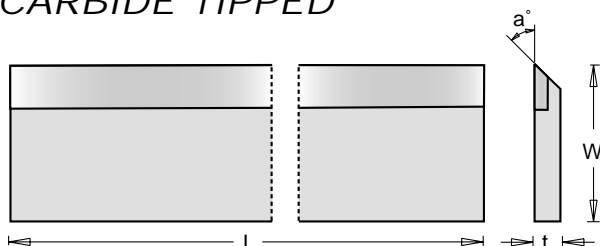

An economical alternative to solid carbide knives. Longer tool life than standard HSS knives.

Tool No.	L	W	t	a°
CTP-100	4	3/4	1/8	45°
CTP-110	6	5/8	1/8	45°
CTP-120	6	3/4	1/8	45°
CTP-130	8	5/8	1/8	45°
CTP-140	8	3/4	1/8	45°
CTP-150	12	3/4	1/8	45°

PORTABLE PLANER KNIVES SOLID CARBIDE

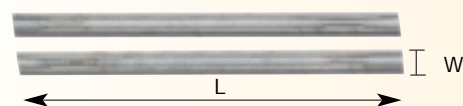

New solid carbide reversible knives designed for many popular 3-1/4" machines.

The **ICK-100** (82mm) will fit many models by AEG, BOSCH, HITACHI, MAKITA, METABO, RYOBI, SKIL, etc.

The **ICK-200** (82.7mm) will fit many models by Black & Decker.

Includes one pair of 2-sided (reversible) knives.

Tool No.	L	W	Thickness
ICK-100	82.0MM (3-1/4")	5.5MM	1.12MM
ICK-200	82.7MM (3-1/4")	5.5MM	1.12MM

CORRUGATED BACK MOULDER STEEL M-2 High-speed Steel (HSS)

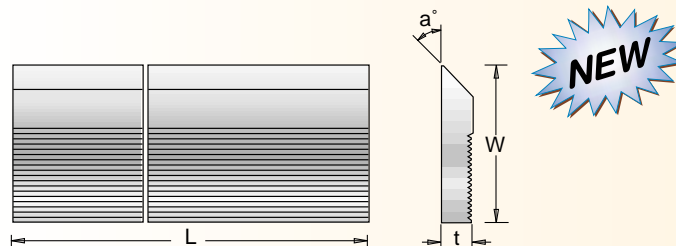
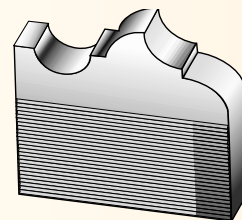

Tool No.	Tool No.	L	t	a°
t = 1/4"	t = 5/16"			
CSK-100	CSK-300	25	1-1/4	45°
CSK-110	CSK-310	25	1-1/2	45°
CSK-120	CSK-320	25	1-3/4	45°
CSK-130	CSK-330	25	2	45°
CSK-140	CSK-340	25	2-1/4	45°
CSK-150	CSK-350	25	2-1/2	45°
CSK-160	CSK-360	25	2-3/4	45°
CSK-170	CSK-370	25	3	45°

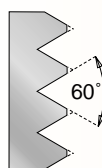

PLANER / MOULDER HEADS 4-wing with M-2 HSS Knives

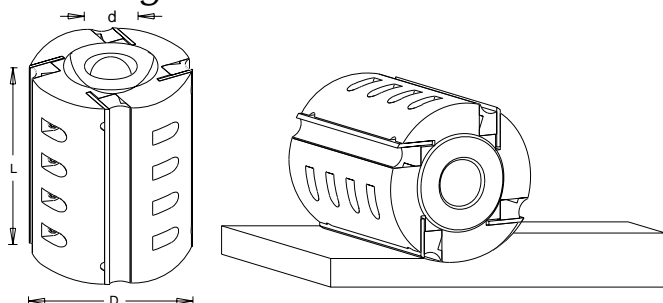

Products shown in **Bold** indicate most popular items.

Tool No.	D	L	d	Replacement	
				Set of 4 Knives 30MM x 3MM x L	Wedges (ea.) 4 Required 25MM x 15MM x L
61700	125MM	100MM	1-1/4	P 120	WB-80
61702	125MM	100MM	30MM	P 120	WB-80
61704	125MM	130MM	1-1/4	P 140	WB-82
61706	125MM	130MM	30MM	P 140	WB-82
61708	125MM	150MM	1-1/4	P 180	WB-84
61710	125MM	150MM	30MM	P 180	WB-84
61712	125MM	180MM	1-1/4	P 240	WB-86
61714	125MM	180MM	30MM	P 240	WB-86
61716	125MM	230MM	1-1/4	P 345	WB-88
61718	125MM	230MM	30MM	P 345	WB-88

Replacement screws M8 x 16MM #67196.

Replacement springs #67198.

Replacement 4MM allen key #5010.